



# GAMYU

## Hualapai Election Board • 2020 Candidate List

Submitted by: Rison Walker | Hualapai Election Board

### Inside this issue:

Information & Events	2
Employment	32
Health & Safety	33
Community Messages	41



Hualapai Election Board  
P.O. Box 119  
Peach Springs, AZ 86434

### 2020 Elections Candidate List

#### **SPECIAL POINTS OF INTEREST:**

- ◆ Stay at Home Order Notice and Resolution(s), page 3.
- ◆ Incident Response Team Updates, page 11.
- ◆ Human Resources Administrative Leave Memo and Sick Leave Form, page 16.
- ◆ Diamond Creek Restaurant new hours and limited menu, see page 29.
- ◆ For more Text Alert updates, text HUALAPAI1 to 91896.
- ◆ To all workers who serve our community and keep us healthy. We see you and we thank you.

#### **Chairperson**

1. Clarke, Damon
2. Havatone, Earlene
3. Imus, Carrie
4. Majenty, Rory

#### **Vice Chairperson**

1. Crozier, Shelton Scott
2. Crozier, Stewart
3. Quasula Sr., Ronald

#### **Council Seat**

1. Crozier, Shelton Scott
2. Crozier, Stewart
3. Havatone, Earlene
4. Imus, Carrie
5. Lee, Crystal Lana
6. Majenty, Rory
7. Pagilawa, Marietta Jean
8. Parker, Vivian Sue
9. Quasula Sr., Ronald
10. Walema, Angeline
11. Whatoname, Howard

Subject to change.

# **ELECTION**

# **NOTICE**

POSTED: March 17, 2020

## **Primary Election**

*Voting for Chairperson and Vice-Chairperson*

**Where: Multi-Purpose Building**

**When: Thursday, May 7, 2020**

**Time: 8:00 am to 5:00 pm**

*\*Counting and finalization of ballots to begin after the closing of the voting polls.*

## **General Election**

*Voting for Chairperson, Vice-Chairperson and 3 Council Members*

**Where: Multi-Purpose Building**

**When: Saturday, June 6, 2020**

**Time: 8:00 am to 5:00 pm**

*\*Counting and finalization of ballots to begin after the closing of the voting polls.*

*-Absentee Voting is permitted in upcoming elections.*

Tasha Nez  
*Judge*

Rison Walker  
*Marshall*

Cortney Beecher  
*Secretary*

Flora Selana  
*Clerk*

Brenda Martin  
*Clerk*

Debora Saganitso  
*Clerk*

Barbara Tinhorn  
*Elderly Liaison*

## Hualapai Tribe • Stay at Home Order Notice

Submitted by: Hualapai Incident Response Team

The Great Spirit created Man and Woman in his own image. In doing so, both were created as equals. Both depending on each other in order to survive. Great respect was shown for each other, in doing so, happiness and contentment was achieved then, as it should be now.

The connecting of the Hair makes them one person, for happiness or contentment cannot be achieved without each other.

The Canyons are represented by the purples in the middle ground, where the people were created. These canyons are Sacred, and should be so treated at all times.

The Reservation is pictured to represent the land that is ours, treat it well.



The Reservation is our heritage and the heritage of our children yet unborn. Be good to our land and it will continue to be good to us.

The Sun is the symbol of life, without it nothing is possible - plants don't grow - there will be no life - nothing. The Sun also represents the dawn of the Hualapai people. Through hard work, determination and education, everything is possible and we are assured bigger and brighter days ahead.

The Tracks in the middle represent the coyote and other animals which were here before us.

The Green around the symbol are pine trees, representing our name Hualapai - PEOPLE OF THE TALL PINES.

### HUALAPAI TRIBE OFFICE OF THE CHAIRPERSON

P.O. Box 179 / 941 Hualapai Way • Peach Springs, Arizona 86434

(928) 769-2216 • 1-888-769-2221

*Damon R. Clarke, Ed.D.*  
Chairman

*Philbert Watahomigiz, Sr.*  
Vice Chairman

Date: April 10, 2020

#### Hualapai Community Members

Hualapai Tribal Citizens of the community of Peach Springs; and all surrounding areas. The Hualapai Tribal Council activated the Incident Command Team, to follow their lead to protect the Hualapai Community from COVID-19.

**The Hualapai Tribal Council went on record, April 9, 2020, to adopt Resolution 27-2020 Temporary Declaration of Emergency measure Order for COVID-19. The Stay at Home Order will come in effect, Saturday, April 11, 2020, beginning at 8:00 pm.**

#### The Stay at Home Order:

Stay within the boundary of your property and limit direct communication with the public to avoid potential contact with COVID-19. The exception is medical care, food, financial obligations, essential employees, and tribal officials. If the Stay at Home Order is not followed you put the community at risk of virus spread.

**Curfew Hours: 8:00 PM – 5:00 AM**

**Offense 1: Written/Verbal Warning**

**Offense 2: \$200 fine deducted from payroll or per cap and non-members removed from the Hualapai Reservation for 1 year**

**Offense 3: Up to 30 days of imprisonment and additional \$200.00 fine deducted from payroll or per cap.**

The ICT has been working diligently to protect the Hualapai Tribe and its members from the virus. Please continue to practice cleanliness, sanitation, social distancing, and voluntary self-isolation as recommended by the CDC. *Limit your time off the reservation.*

Let's continue to protect the Hualapai Legacy, together, by STAYING HOME!

Hank yu,

Dr. Damon R. Clarke, Chairman  
Hualapai Tribal Council

**Hualapai Incident Management • Administrative Leave Memo**

*Submitted by: Hualapai Incident Response Team*

*Our priority is the safety and health of the Hualapai Tribe. The Incident Management Team along with all of tribal departments and Indian Health Services are working together to prepare and respond to COVID-19 cases.*



**INCIDENT MANAGEMENT**

**CLARITY ON THE STAY AT HOME ORDER  
PER RESOLUTION 27-2020**

**ATTENTION:** The Stay at Home Order is in effect **24 hours a day.**

And, the Order says;

*“Stay within the boundary of your property and limit direct communication with the public to avoid potential contact with COVID-19.”*

Exceptions to the Order;

- Medical care
- Food
- Financial obligations
- Essential employees
- Tribal officials

It is important to understand the reasoning behind this order. The Stay at Home Order is to prevent exposure to others and to protect you and your family. If the Stay at Home Order is not followed, **you put the community at risk of virus spread.**

The **CURFEW HOURS** of **8:00 PM to 5:00 AM** are meant for all members to remain indoors between those hours to prevent the spread of COVID-19.

<b>Offense 1</b>	<b>Written/Verbal Warning</b>
<b>Offense 2</b>	<b>\$200 Fine deducted from payroll or percap. Non-members removed from the Hualapai Reservation for 1 year</b>
<b>Offense 3</b>	<b>Up to 30 days of imprisonment and additional \$200 Fine deducted from payroll or percap</b>

**Isolation** – separates sick people with a contagious disease from people who are not sick.

**Quarantine** – Separates and restricts the movement of people who were exposed to a contagious disease to see if they become sick.

For those **who are under quarantine** and violate the curfew, the offenses step up.

<b>Offense 1</b>	<b>\$200 Fine deducted from payroll or percap. Non-members removed from the Hualapai Reservation for 1 year</b>
<b>Offense 2</b>	<b>Up to 30 days of imprisonment and additional \$200 Fine deducted from payroll or percap</b>
<b>Offense 3</b>	<b>Up to 30 days of imprisonment and 1 year loss of percap</b>

Isolation and quarantine **help protect the public** by preventing exposure to people who have or may have a contagious disease. Let's work together to protect our families. Be safe.

HUALAPAI TRIBAL COUNCIL  
**RESOLUTION 26-2020**  
OF THE GOVERNING BODY  
OF THE HUALAPAI TRIBE OF THE HUALAPAI RESERVATION

**Temporary Amendment of Section 6.92 (Endangerment)  
of the Tribal Law & Order Code Regarding COVID-19**

**WHEREAS,** the Hualapai Tribe is a federally recognized Indian Tribe located on the Hualapai Indian Reservation in Northwestern Arizona; and

**WHEREAS,** the Hualapai Tribal Council has the power to represent the Tribe and act in all matters that concern the welfare of the Tribe pursuant to Article V(r) of the Hualapai Constitution; and

**WHEREAS,** the Hualapai Tribe declared a State of Emergency in connection with COVID-19 on March 16, 2020; and

**WHEREAS,** the Tribal Incident Command Team (ICT) is preparing the support the Hualapai Community as part of the ICT COVID-19 Response Plan through implementation of isolation, Stay-At-Home Orders, Quarantine Orders, and a curfew, which requires an enforcement provision for such a Response Plan; and

**WHEREAS,** the ICT has consulted with Hualapai Nation Police Department, the Hualapai Prosecutor's Office, Legal Counsel of the Hualapai Tribe, and the Hualapai Tribal Court, and has made the recommendation that these amendments be enacted in order to establish enforcement provisions per the ICT COVID-19 Response Plan;

**THEREFORE BE IT RESOLVED,** the Hualapai Tribal Law & Order Code is hereby amended as follows:

Section 6.92 shall be temporarily amended with the following:

**"Section 6.92 Endangerment**

A person commits endangerment:

- (A) By recklessly engaging in any conduct which places another person at substantial risk of imminent death or bodily harm; or

(B) By knowingly refusing or failing to obey any Declaration of Emergency Measure Order, or any provisions thereof, that is in effect pursuant to action of the Hualapai Tribal Council.

A person guilty of this offense may be sentenced to imprisonment for a period not to exceed 90 days or a fine not to exceed \$2,000, or both.”

**NOW THEREFORE BE IT FINALLY RESOLVED**, that the Tribal Council hereby enacts this Temporary Amendment to Section 6.92 (Endangerment) to the Tribal Law & Order Code.

#### CERTIFICATION

I, the undersigned as Chairman of the Hualapai Tribal Council hereby certify that the Hualapai Tribal Council of the Hualapai Tribe is composed of nine (9) members of whom nine (9) constituting a quorum were present at Special Council Meeting, thereof held on this 9<sup>th</sup> day of April, 2020; and that the foregoing resolution was duly adopted by the affirmative vote of (6) approve, (3) opposed, (0) not voting, (0) excused, pursuant to the authority of Article V, Section (a) of the Constitution of the Hualapai Tribe approved March 13, 1991.



Dr. Damon R. Clarke, Chairman  
Hualapai Tribal Council

ATTEST:

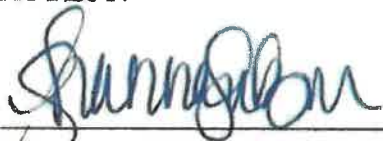

Shanna Salazar, Administrative Assistant  
Hualapai Tribal Council

HUALAPAI TRIBAL COUNCIL  
**RESOLUTIO 27-2020**  
OF THE GOVERNING BODY  
OF THE HUALAPAI TRIBE OF THE HUALAPAI RESERVATION

**Temporary Declaration of Emergency Measure Order for COVID-19**

**WHEREAS,** the Hualapai Tribe is a federally recognized Indian Tribe located on the Hualapai Indian Reservation in Northwestern Arizona; and

**WHEREAS,** the Hualapai Tribal Council has the power to represent the Tribe and act in all matters that concern the welfare of the Tribe pursuant to Article V(r) of the Hualapai Constitution; and

**WHEREAS,** the Hualapai Tribe declared a State of Emergency in connection with COVID-19 on March 16, 2020; and

**WHEREAS,** the Tribal Incident Command Team (ICT) has prepared an Emergency Measure Order's listed below to protect the Hualapai community by limiting exposure to COVID -19 and to limit community movement;

**WHEREAS,** the orders are listed below which coincide with offenses

**Stay at Home Order – Stay within the boundary of your property and limit direct communication with the public to avoid potential contact with COVID-19. The exception is medical care, food, financial obligations, essential employees, and tribal officials. If the Stay at Home Order is not followed you put the community at risk of virus spread.**

Curfew Hours: 8:00PM – 5:00AM

Offense 1: Written/Verbal Warning

Offense 2: \$200.00 fine deducted from payroll or per cap and non-members removed from the Hualapai reservation for 1 year

Offense 3: Up to 30 days of imprisonment and additional \$200.00 fine deducted from payroll or per cap

**Isolation - Separates sick people with a contagious disease from people who are not sick.**

**Quarantine – Separates and restricts the movement of people who were exposed to a contagious disease to see if they become sick.**

Offense 1: \$200.00 fine deducted from payroll or per cap and non-members removed from the Hualapai reservation for 1 year

Offense 2: Up to 30 days of imprisonment and additional \$200.00 fine deducted from payroll or per cap

Offense 3: Up to 30 days of imprisonment and 1-year loss of per cap

**THEREFORE BE IT RESOLVED**, the Chairman or the delegation of authority to the ICT is authorized to implement such measures.

**CERTIFICATION**

I, the undersigned as Chairman of the Hualapai Tribal Council hereby certify that the Hualapai Tribal Council of the Hualapai Tribe is composed of nine (9) members of whom nine (9) constituting a quorum were present at Special Council Meeting, thereof held on this 9<sup>th</sup> day of April, 2020; and that the foregoing resolution was duly adopted by the affirmative vote of (8) approve, (1) opposed, (0) not voting, (0) excused, pursuant to the authority of Article V, Section (a) of the Constitution of the Hualapai Tribe approved March 13, 1991.



Dr. Damon R. Clarke, Chairman  
Hualapai Tribal Council

ATTEST:

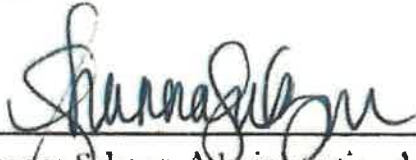

Shanna Salazar, Administrative Assistant  
Hualapai Tribal Council



**HUALAPAI TRIBAL COUNCIL**  
**RESOLUTION 29-2020**  
**OF THE GOVERNING BODY**  
**OF THE HUALAPAI TRIBE OF THE HUALAPAI RESERVATION**

**Amendment to Resolution 27-2020 Temporary Declaration of Emergency Measure Order for COVID-19**

**WHEREAS,** the Hualapai Tribe is a federally recognized Indian Tribe located on the Hualapai Indian Reservation in Northwestern Arizona; and

**WHEREAS,** the Hualapai Tribal Council has the power to represent the Tribe and act in all matters that concern the welfare of the Tribe pursuant to Article V(r) of the Hualapai Constitution; and

**WHEREAS,** the Hualapai Tribe declared a State of Emergency in connection with COVID-19 on March 16, 2020; and

**WHEREAS,** the Tribal Incident Command Team (ICT) has prepared an Emergency Measure Order's listed below to protect the Hualapai community by limiting exposure to COVID -19 and to limit community movement;

**WHEREAS,** the Hualapai Tribal Police Department, and any other authorized commissioned officer to issue a citation as a civil sanction;

**WHEREAS,** the orders are listed below which coincide with offenses

**Stay at Home Order – Applies 24 hours/7 days a week for all community members to stay within the boundary of their property and limit direct communication with the public to avoid potential contact with COVID-19. The exception is medical care, food, financial obligations, essential employees, and tribal officials. NO riding in vehicles without essential reason, during the day. Cattle associations and tribal contractors are to stop by Tribal Game & Fish to receive a placard to conduct official business. If the Stay at Home Order is not followed you put the community at risk of virus spread.**

**Curfew Hours: 8:00PM – 5:00AM (All community members to be indoors)**

**Offense 1: Written Warning**

**Offense 2: Shall be fined \$300 to be deducted from payroll or Hualapai Distribution and non-members removed from the Hualapai reservation for 1-year**

**Offense 3: Shall be imprisoned for 30-days and an additional \$300.00 fine shall be imposed, deducted from payroll or Hualapai Distribution**

**Isolation - Separates sick people with a contagious disease from people who are not sick.**

**Quarantine - Separates and restricts the movement of people who were exposed to a contagious disease to see if they become sick.**

Offense 1: Shall be \$300.00 fine deducted from payroll or Hualapai Distribution and non-members removed from the Hualapai reservation for 1-year

Offense 2: Shall be 30-days of imprisonment and additional \$300.00 fine deducted from payroll or Hualapai Distribution

Offense 3: Shall be imprisonment of 30-days and 1-year loss of Hualapai Distribution

**THEREFORE BE IT RESOLVED**, the Chairman or the delegation of authority to the ICT is authorized to implement such measures.

#### CERTIFICATION

I, the undersigned as Chairman of the Hualapai Tribal Council hereby certify that the Hualapai Tribal Council of the Hualapai Tribe is composed of nine (9) members of whom nine (9) constituting a quorum were present at Special Council Meeting, thereof held on this 16<sup>th</sup> day of April, 2020; and that the foregoing resolution was duly adopted by the affirmative vote of (9) approve, (0) opposed, (0) not voting, (0) excused, pursuant to the authority of Article V, Section (a) of the Constitution of the Hualapai Tribe approved March 13, 1991.

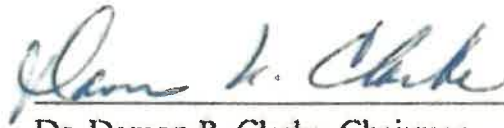

Dr. Damon R. Clarke, Chairman  
Hualapai Tribal Council

ATTEST:



Shanna Salazar, Administrative Assistant  
Hualapai Tribal Council

**Hualapai Response Team • Community & County Update***Submitted by: Hualapai Incident Response Team*

*Our priority is the safety and health of the Hualapai Tribe. The Incident Management Team along with all of tribal departments and Indian Health Services are working together to prepare and respond to COVID-19 cases.*



## INCIDENT MANAGEMENT

### PRESS RELEASE

**DATE:** 4/14/2020

**TIME:** 3:30 PM

**FROM:** Incident Commander

Health Officials Confirm there are seven (7) Peach Springs community members have Tested Positive for COVID-19. Some individuals are currently hospitalized and other members are self-quarantined.

We encourage community members to remain calm, and take this matter seriously and be aware this case may be a result of "community spread." Please continue following CDC recommendations at home and refrain from visiting other homes unless necessary. As you make necessary visits consider elderly and youth.

As defined by the CDC, community spread means people have been infected with the virus in an area, including some who are not sure how or where they became infected.

The best ways to prevent the spread of COVID-19:

- Wash hands often with soap and water for at least 20 seconds, or use sanitizer
- Avoid touching eyes, nose, and mouth with unwashed hands. Avoid people who are sick.
- Be responsible: stay home if sick, or get checked by a medical professional.
- Clean and disinfect objects and surfaces. COVID-19 spreads through mucus droplets through coughs or sneezes. Symptoms appear within 2 to 14 days after exposure and consist of fever, cough, runny nose, and difficulty breathing.

For people with mild illness, individuals are asked to stay home, drink plenty of fluids, and get rest. For people with more severe symptoms, such as shortness of breath, individuals are advised to seek healthcare at IHS or EMS

**MOHAVE  
COUNTY****PRESS RELEASE**ROGER GALLOWAY, Communications Director  
(928) 757-0940 Ext 5940

***County Health Officials Confirm  
1 New Positive Case in Kingman  
It Brings Total in County to 51  
2 Earlier Deaths Are Included***

MOHAVE COUNTY, AZ (April 15, 2020) – The Mohave County Health Department MCDPH-Nursing staff was notified this afternoon of another positive COVID-19 case in the Kingman service area. This individual is in the 20-44 age range, is in isolation and is recovering at home. Nurses will initiate the contact investigation soon; At this time it cannot be determined if the case is epidemiologically-linked to another case or travel-related.

This new case brings to 51 the total positives in Mohave County. There are now 18 positive confirmed cases in the Lake Havasu City area, including two earlier deaths, 29 in Kingman, and 4 in Bullhead City.

The best ways to prevent the spread of COVID-19:

Please remember to keep your Social Distancing – At least 6 Feet apart! Stay at home if at all possible.

***Here is some important advice about face masks –***

The CDC is recommending that people wear *cloth* face masks to help prevent the spread of COVID-19 from those who may have the virus, but are not experiencing any symptoms. Research shows that [people without symptoms](#) can infect others and that the virus may spread when people [speak or breathe](#) — not just when they cough or sneeze. “In light of this new evidence, the CDC recommends that people wear cloth face coverings in public settings where other distancing measures are difficult to maintain,” US Surgeon General Adams said.

CDC advises the use of a simple cloth face mask to help slow the spread of COVID-19. These face masks should fit snugly against the side of the face, be secured with ties or ear loops, include multiple layers of cloth, allow breathing without restriction, and be machine washable, without causing damage to the shape or size of the mask. Cloth masks should be washed regularly; a washing machine should suffice for cleaning. When removing the mask, everyone should be careful not to touch eyes, nose, or mouth, and wash hands immediately after mask removal.

The cloth face masks recommended are *not* surgical masks or N-95 respirators. These are critical supplies that should be reserved for healthcare workers, first responders, and other emergency personnel.

The cloth face mask doesn't replace the need for frequent handwashing, covering coughs and sneezes, or the practice of physical distancing. Face masks should not be placed on young children under 2, anyone who has trouble breathing, or are unable to remove the mask without assistance. For more information about wearing a mask, please visit the CDC's website at: <https://www.cdc.gov/coronavirus/2019-ncov/prevent-getting-sick/diy-cloth-face-coverings.html>

ALSO ---

- Wash your hands often with soap and water for at least 20 seconds. If soap and water are not available, use an alcohol-based hand sanitizer.
- Avoid touching your eyes, nose, and mouth with unwashed hands.
- Avoid close contact with people who are sick.
- Stay home when you are sick, or if you are a not an essential employee.
- Cover your cough or sneeze with a tissue, then immediately throw the tissue in the trash.
- Clean and disinfect frequently touched objects and surfaces.

COVID-19 spreads through the air when an infected person coughs or sneezes. Symptoms are thought to appear within two to 14 days after exposure and consist of fever, cough, runny nose, and difficulty breathing. For people with mild illness, individuals are asked to stay home, drink plenty of fluids, and get rest. For people with more severe symptoms, such as shortness of breath, individuals are advised to seek healthcare, using telemedicine where available.

Mohave County activated its Health Department Operations Center on February 1, 2020, after the first case of travel-associated COVID-19 was confirmed in Arizona. The Health Department Operations Center remains open to coordinate the County's response to the COVID-19 outbreak.

For more information about the COVID-19 response in Arizona, go online to: <https://azdhs.gov/>

For more detailed information about COVID-19 in Mohave County, please visit <https://covid-19-mohave.hub.arcgis.com/>.

Hualapai Tribe—Resolution 25-2020 • COVID-19 Response Plan  
Submitted by: Kevin Davidson | Hualapai Planning Department Per Incident Command Team

HUALAPAI TRIBAL COUNCIL  
**RESOLUTION 25-2020**  
OF THE GOVERNING BODY OF THE  
OF THE HUALAPAI TRIBE OF THE HUALAPAI RESERVATION

**COVID-19 Response Plan**

**WHEREAS,** the Hualapai Tribe is a federally recognized Indian Tribe located on the Hualapai Indian Reservation in Northwestern Arizona; and

**WHEREAS,** the Hualapai Tribal Council has the power to represent the Tribe and act in all matters that concern the welfare of the Tribe pursuant to Article V (r) of the Hualapai Constitution; and

**WHEREAS,** the Incident Command Team was initiated on March 17<sup>th</sup>, 2020 per Resolution No. 18-2020. The intent of the team is to educate the community regarding COVID-19 spread, recognizing symptoms, taking individual responsibility, and knowing what to do if you feel ill. Intent also include the develop of a COVID-19 Response Plan which all information is based on community infrastructure, demographics, and the Center for Disease Control and Prevention’s recommendations

**WHEREAS,** the plan is complete and will continue to be evaluated based on CDC’s research, recommendations, and Tribal Council’s guidance.

**NOW THEREFORE BE IT FINALLY RESOLVED,** that the Chairman approve the COVID-19 Response Plan and updates can be modified by the Incident Commander based on evolving research and safety of the Hualapai community.

**CERTIFICATION**

I, the undersigned as Chairman of the Hualapai Tribal Council hereby certify that the Hualapai Tribal Council of the Hualapai Tribe is composed of nine (9) members of whom nine (9) constituting a quorum were present at a Special Council Meeting thereof held on this 9<sup>th</sup> day of April, 2020; and that the foregoing resolution was duly adopted by the affirmative vote of (9) approve, (0) opposed, (0) excused, pursuant to the authority of Article V, Section (a) of the Constitution of the Hualapai Tribe approved March 13, 1991.

ATTEST:

  
Shanna Salazar, Administrative Assistant  
Hualapai Tribal Council

  
Dr. Damon R. Clarke, Chairman  
Hualapai Tribal Council

# RECEIVING DONATIONS THROUGH THE INCIDENT COMMAND TEAM

Donations are a great way for our community to come together in a time of need. It is greatly appreciated by the receiver and gives you a way to participate in helping others out.

But, be aware that a quick prescreen procedure is needed to determine a reasonable stewardship of the donated items prior to their acceptance here, and provides some practical documentation for the Tribe.

Be prepared to give us the following information...

1. **Who** is giving the donation?
2. **What** are the donated items?
3. Are the donated items being **shipped**, or **dropped off in person**?
4. Our business hours for accepting donations are; **10:00 AM to 3:00 PM**
5. Bring or ship your donation to the FORESTRY OFFICE at 1130 Mesa View Dr, Peach Springs, AZ 86434. Or, call the Public Information Line (928) 769-2312
6. Please let us know **any handling requests** if the donation is; for a specific person or home, for a group, is fragile, perishable, requires refrigeration, or needs to be kept dry.
7. Please be advised that any hot or prepared foods, flammable materials, medicines or controlled substances needing special handling **may be refused** unless approved by the IC.

**DISCLAIMER:** The Incident Command Team DOES NOT imply a guarantee or have a warranty of any kind for donated items. Any donated item used or misused may have an unintended potential for risk of injury to body and health. Any donated items taken or used by the end receiver of any donations are at the discretion of the end receiver.

Feel free to call us about your donation

Thank you

## Hualapai Human Resources Department • Administrative Leave Memo

Submitted by: Kevin Davidson | Hualapai Planning Department



Hualapai Human Resources Department  
 P.O. Box 179 941 Hualapai Way  
 Peach Springs, AZ 86434  
 (P) 928-769-2216 (F) 928-769-1191

4/10/2020

From: Travis Godwin, HR Director

To: All Tribal Employees

Subj: Administrative Leave due to Coronavirus (COVID-19) Cont. & Potential Furlough

Ref: (1) Hualapai Tribal Council Resolution No. 19-2020 & 23-2020

(2) Hualapai Personnel, Policies & Procedures Manual, Ch. 12.8.

(3) Tribal Council Meeting, DTD 4/9/2020

1. **Leave Period:** As per Hualapai Tribal Council Resolution No. 19-2020, 23-2020 and Tribal Council Motion on 4/9/2020; non-essential Tribal Employees will be on continued **Paid Administrative Leave from 4/12/2020 up through 5/2/2020.** This period covers 22 calendar days. However, the paid number of days will coincide with the number of days that would have been normally worked had this leave period not been granted. This period of administrative leave is an effort to limit the potential spread of and exposure to the Coronavirus (COVID-19).

2. **Paid Administrative Leave is limited to non-essential personnel only:** It is up to each Department Director to determine exactly who in the department is considered non-essential. It is the intent of the resolution to limit employees coming in to the normal work place to the maximum extent possible. Directors must determine essential functions and then determine the bare minimum employees necessary to carry out those functions. Non-essential personnel lists have already been received and do not need to be provided at this time.

3. **Working from home & Recalled while on Admin Leave:** During this period any employee who is on paid administrative leave is subject to working from home and subject to being called to come in to the workplace on a limited basis. **Employees that refuse to comply with a Director's request to work face potential disciplinary measures.** It is up to the Director to determine whether an employee can work from home or not. Directors must work with employees to come up with schedules etc. to manage the department as effectively as possible. Schedules do not need to be sent to HR for approval. Ensure that actions and plans fall in line with limiting the potential spread of and exposure to the Coronavirus (COVID-19).

4. **Travel:** It is the intent of the Paid Administrative Leave period and the resolution to limit the potential spread of and exposure to the Coronavirus (COVID-19). During this period, any

Coleen Mahone  
Technician

Travis Godwin  
Director

Sonja Crozier  
Assistant

Veronica Cabrera  
Process Data Collector



personal travel that is beyond a reasonable distance which goes against the intent of the resolution may be charged as personal leave and may be accompanied by disciplinary measures.

5. **Emergency Sick Leave:** Guidance on how to apply for and handle Sick Leave that is related to COVID-19 during this Admin Leave Period will be sent out next week. In the meantime, employees should attempt to inform Supervisors & Directors if dealing with COVID-19 related issues.

6. **Pay Period 9:** If an employee has worked or will work in the normal setting for any amount of time, a signed timesheet is required for that employee showing their hours worked and the amount of Admin Leave taken. Turn those timesheets in as normally scheduled to the payroll office. If you have any questions regarding how to fill out said timesheets for those employees, please refer those questions to the payroll office as well. Timesheets are not required if the employee was on Admin Leave only during this period of time.

7. **Pay Period 10:** Paid Admin Leave has been extended only half-way through this pay period. Plan to keep track of Admin Leave and Actual Hours Worked during the first week of this pay period and conduct the second half as normal. If the status of Paid Admin Leave changes prior to this another memo will be generated.

8. **Potential Furloughs:** If Furloughs are required they will not start until the beginning of Pay Period 10, 4/26/2020. If you are an employee that will be affected by a Furlough you can expect to receive a Personal Furlough Letter from HR and to be notified well in advance of the Furlough.



Travis Godwin

Coleen Mahone  
Technician

Travis Godwin  
Director

Sonja Crozier  
Assistant

Veronica Cabrera  
Process Data Collector



Hualapai Human Resources Department  
P.O. Box 179            941 Hualapai Way  
Memorandum No. 25-20  
Peach Springs, AZ 86434  
(P) 928-769-2216            (F) 928-769-1191

---

4/14/20

From:            Travis Godwin, Director  
                    Human Resources  
To:                All Tribal Employees  
Subj:             **Emergency COVID-19 Leave**  
Ref:                (1) Hualapai Personnel Policies & Procedures Manual Ch. 12.3, Sick Leave  
                    (2) Tribal Council Motion, DTD 4/16/2020  
Encl:              (1) Emergency COVID-19 Leave Request Form

1. Effective April 1<sup>st</sup>, 2020, Hualapai Tribal Council has expanded its definition of Paid Sick Leave to include leave for **Emergency COVID-19** related reasons and has included a list of qualifying reasons and procedures. This expanded definition is applicable between April, 1<sup>st</sup>, 2020 and December, 31<sup>st</sup>, 2020.
2. Emergency COVID-19 Leave, entitles certain employees to take up to two weeks (80 hours) of Emergency COVID-19 Leave.
3. Reasons for Leave:
  - a. The employee is subject to a federal, state, or local quarantine or isolation order related to COVID-19;
  - b. The employee has been advised by a health care provider to self-quarantine because of COVID-19;
  - c. The employee is experiencing symptoms of COVID-19 and is seeking a medical diagnosis from a health care provider;
  - d. The employee is caring for an individual (immediate family member) subject or advised to quarantine or isolation;
  - e. The employee is caring for a son or daughter whose school or place of care is closed, or child care provider is unavailable, due to COVID-19 precautions; or
  - f. The employee is experiencing substantially similar conditions as specified by the Secretary of Health and Human Services, in consultation with the Secretaries of Labor and Treasury.
4. Amount of Leave:
  - a. Full-Time Employees are entitled to 80 hours of Emergency COVID-19 Leave.

- b. Part-Time Employees are entitled to up to the number of hours equal to the number of hours that the employee is normally scheduled to work over two workweeks.
  - c. A Full-Time or Part-Time Employee is **NOT** subject to a minimum amount of continuous days employed to be eligible for Emergency COVID-19 Leave. Under normal circumstances an employee would have to wait a minimum of 30 days in order to be eligible to take Sick Leave as per Ref. (1).
5. Notice Requirements:
- a. Where leave is foreseeable, an employee should provide notice of their need for Emergency COVID-19 Leave to their supervisor as soon as applicable.
  - b. Notice is not required in advance. However, notice is required after the first workday for which an employee takes Emergency COVID-19 Leave. An employee's spouse, adult family member, or other responsible party may provide written notice if the employee is unable.
6. Required Documentation:
- a. A doctor's note or an official notice from a closed school or daycare is not required.
  - b. An Emergency COVID-19 Leave form, Encl. (1), **IS REQUIRED** and constitutes the "Notice Requirements" described above.

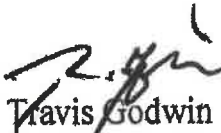

Travis Godwin

# EMERGENCY COVID-19 LEAVE REQUEST FORM

Employee Name	Employee ID Number	Date
Title	Supervisor	Department
Leave Start Date	Leave End Date	Total Hours Requested

I CERTIFY THAT AM UNABLE TO WORK (OR TELEWORK) FOR THE FOLLOWING REASON:

I am subject to a **federal, state, or local quarantine or isolation order** related to COVID-19 that specifically prevents me from working.

Name of the government entity issuing the order:

I have been **advised by a health care provider to self-quarantine** because of concerns related to COVID-19.

Name of the advising healthcare provider:

I have **symptoms of COVID-19** and I am seeking (or have sought) a diagnosis.

I am **caring for another individual** who is subject to quarantine or has been advised by a health care provider to self-quarantine related to COVID-19.

Name of person I am caring for and our relationship:

Name of the government entity issuing the order:

**OR**

Name of the advising healthcare provider:

I **need to care for my child(ren)** because their school or childcare provider is closed or unavailable because of COVID-19. I certify that **no other suitable person is available to care for the child(ren) during the period of requested leave.** If listed child is over 14, I further certify that there are special circumstances that require me to provide care for them.

Name(s) and age(s) of child(ren):

Name of closed school(s) or place(s) of care:

I am experiencing **other conditions substantially similar to COVID-19** as specified by the Department of Health and Human Services.

**I certify that the above information is truthful and understand that misrepresenting my need for leave is grounds for discipline, up to and including termination.**

Employee Signature:

If signing electronically, please type your full name, followed by "e-signed."

## Hualapai Education & Training Center • Notice to Potential and Current College Students

Submitted by: Hualapai Incident Response Team

The Great Spirit created Man and Woman in his own image. In doing so, both were created as equals. Both depending on each other in order to survive. Great respect was shown for each other; in doing so, happiness and contentment was achieved then, as it should be now.

The connecting of the Hair makes them one person; for happiness or contentment cannot be achieved without each other.

The Canyons are represented by the purples in the middle ground, where people were created. These canyons are Sacred, and should be treated so at all times.

The Reservation is pictured to represent the land that is ours, treat it well.



The Reservation is our heritage and the heritage of our children yet unborn. Be good to our land and it will continue to be good to us.

The Sun is the symbol of life, without it nothing is possible – plants don't grow – there will be no life – nothing. The Sun also represents the dawn of the Hualapai people.

Through hard work, determination and education, everything is possible and we are assured bigger and brighter days ahead.

The Tracks in the middle represent the coyote and other animals which were here before us.

The Green around the symbol are pine trees, representing our name Hualapai – PEOPLE OF THE TALL PINES \_

# Notice from Hualapai Education & Training Center

## Notice to Potential and Current College Students,

Due to the global COVID-19 Pandemic the world is facing, the Hualapai Education Committee has made a motion on 4/10/20 to continue with funding for Summer 2020 semester as followed: tuition fees and books. Fall 2020 semester will be as followed: tuition fees and books ONLY.

The education committee will reevaluate these decisions for the Spring 2021 semester, as we get closer to the deadline, which is January 1. We on the education committee are hoping to have the scholarship back in full funding for Spring 2021.

Thank you for understanding the decision that the education committee had to make during this time of crisis.

Should you have any questions, please contact Jonell Tapija ( [hualapaieducationdepartment@gmail.com](mailto:hualapaieducationdepartment@gmail.com) ). The deadline for sessions is as follows - Summer session is May 1, Fall semester is August 1, and Spring semester is January 1. Please get your applications in as soon as possible, and remember that the education committee will not look at incomplete applications, there are no exceptions. Please stay safe and practice social distancing and clean hygiene.

Han Kyul

Jonell Tapija  
Education Coordinator  
Hualapai Education & Training Center  
P.O. Box 179/460 Hualapai Way  
Peach Springs, AZ 86434  
(928)769-2200 Office  
(928)769-1101 Fax

**Hualapai Housing • Request for Documentation/Income Changes***Submitted by: Hualapai Incident Response Team***HUALAPAI HOUSING**

Hwal'bay Ba:j Wayo:wo'jo

600 Highview Street ♦ P.O. Box 130 ♦ Peach Springs, Arizona 86434

Phone (928) 769-2274 Fax (928) 769-2703



DATE: April 2, 2020

TO: ALL TENANTS

FROM: HOWARD WHATONAME  
RESIDENT SPECIALIST**RE: Request for Documentation/Income changes**

Dear Tenant,

During this time understanding that the Coronavirus (COVID-19) outbreak is impacting the health of Tribal communities, disrupting Tribal economies and changing the way Tribal members live and do business. We also understand that this is having a severe impact on the low-income families assisted under our program. Therefore, we are requesting as soon as possible any changes to your income that COVID-19 has had regarding reduction in hours or loss of employment. So your rent will be adjusted accordingly.

If you have been impacted please provide proof by submitting your P.A. or other documentation you have, there is a drop box in front of the Housing Department. The drop box will be check daily Monday-Friday.

Sincerely,

A handwritten signature in black ink, appearing to read "Howard Whatoname".

*Howard Whatoname*

Resident Specialist

**Hualapai Transit • Face Cover Policy**  
Submitted by: Hualapai Incident Response Team

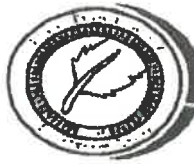

# Hualapai Transit

PO Box 179  
Peach Springs, Arizona 86434  
928-769-6384  
[www.hualapaitransit.org](http://www.hualapaitransit.org)  
[hualapai.transit@hualapai-nsn.gov](mailto:hualapai.transit@hualapai-nsn.gov)

April 14, 2020

In response to the COVID-19 virus situation, Hualapai Transit will no longer be transporting customers who are not wearing a face mask or face cover as indicated below. Passengers without face coverings will be informed of the mandate and will not be transported. If a passenger boards the bus and refuses facial coverings, the passenger will be asked to leave the bus and if the situation persists, authorities will be contacted. Non-compliance with this mandate will result in service denial.

Please note that face coverings may be bandanas, scarves, neck gaiters or other clothing that does not have visible holes.

Hualapai Transit's mission is safety, and we are taking this action to protect the citizens of the Hualapai Tribe as well as the Transit employees.

If you have any questions regarding this matter, please do not hesitate to contact me at 928-769-6090 or [ewright@hualapai-nsn.gov](mailto:ewright@hualapai-nsn.gov).

**Ernie Wright**  
Manager, Hualapai Transit

*Vision: Hualapai Transit is committed to openness and integrity, Hualapai Transit supports the Hualapai Tribes commitment to support the independence of Hualapai Tribal members & surrounding areas and to be a model for excellence by integrating the local spirit and culture.*  
*Mission: Hualapai Transit will provide safe, reliable, friendly and affordable transportation services to meet the mobility needs of the Hualapai Community and surrounding areas while pursuing sustainable development and facilitating the cultural missions of the Peach Springs community.*

Hualapai Stimulus Check • Tribal Members 18 & Over  
Submitted by: Hualapai Incident Response Team

# HUALAPAI STIMULUS

PAPER CHECKS IN THE AMOUNT OF \$500 will be issued from the Hualapai Tribe to ALL Hualapai Tribal Members 18 yrs. and up will be mailed via US Postal Service on Thursday, April 16<sup>th</sup>, 2020. Please go to the [www.hualapai-nsn.gov](http://www.hualapai-nsn.gov) website to update your mailing address.

There will be NO in-person picking up of checks.

Most local members may receive their checks on the following day at the US Post Office. Other members living elsewhere will receive their check according to their regular postal system delivery.

To prevent further exposure and the spread of COVID-19 into our community ALL MEMBERS are encouraged to do MOST or ALL of your essential BANKING needs by using mobile apps on your PHONE or other handheld devices. For those who need to cash .

### For those who have to cash their checks

WELLS FARGO downtown IS CLOSED

WELLS FARGO at Smith's IS CLOSED

WELLS FARGO by Safeway at 3940 Stockton Hill Rd.

- SUNDAY – is Closed
- MONDAY thru FRIDAY – 9:30 AM to 4:00 PM
- SATURDAY – is open 9:00 AM to NOON

ONLY the DRIVE THRU teller is available for business at the WELLS FARGO location and may already be prone to extreme long wait times due to servicing local Kingman business.

OTHER CHECK CASHING options available in the KINGMAN area are;

1. ARIZONA AUTO LENDERS: 3151 N. Stockton Hill Rd – (928) 235-8764
2. CHECK N GO: 1949 E. Beverly Ave. Ste 1 – (928) 757-9500
3. CHECK INTO CASH: 3930 N. Stockton Hill Rd Ste B – (928) 757-0729
4. 1 STOP CHECK CASHING: 3505 N. Stockton Hill Rd – (928) 692-6888
5. ALLIEN CASH ADVANCE: 3990 N. Stockton Hill Rd – (928) 263-8383
6. ACE CASH EXPRESS: 3787 N. Stockton Hill Rd – (928) 692-7110



## Wells Fargo Information

Wells Fargo at Gordon and Stockton Hill in the Safeway parking lot hours M-F 9:30 a-4 p and sat 9 a – 12 p

Cashing Checks at the Gordon Stockton Hill Rd Branch:

- o Branch will staff inside tellers to handle 3 customers at a time in the branch to allow social distancing practices.
- o Branch staff member will allow one person in as one person leaves.
- o We would ask that social distancing be maintained in the parking lot as people are lined up to enter the Branch.
- o Must be understood, there are transactions that cannot be handled in the drive thru, so intermittent customers can be in the mix in the line waiting to get into the Branch.

For all of our customers who have their Wells Fargo Debit Card and a pin number this can serve as their only ID needed when walking into our lobby. A customer face to face with a teller would be able to cash the 500.00 check or deposit with just bringing their debit card, inserting the card into the chip reader and entering their pin

If validating our customers pin number is not possible our Wells Fargo Customers have 3 other possible options:

1. Primary ID (list below) and Authentication questions (questions will be based off their account and will vary) asked by the teller
2. 2 forms of Primary ID's (list below)
3. 1 Primary ID and 1 Secondary (lists below)

**\*NOTE\* All non-customers will fall into either option 2 or 3 above**

### **Acceptable Primary ID's for BOTH Customers and Non-customers**

- o Driver's License
- o State non-driver's license
- o Passport
- o Tribal ID (tribal ID's without a document number are can only be used as a secondary ID)
- o Armed Forces ID
- o Foreign issued ID (example Consular card but must be issued by one of the following countries Argentina, Colombia, Guatemala and Mexico)

### **Acceptable Secondary ID's for Non-customers**

- o ATM Card (from any bank)
- o Credit Card (from any bank)
- o Employer ID (must have document number)
- o Membership Card (must have document number)
- o Student ID
- o Social Security Card

ATM Options:

Accepting Deposits and Withdrawals:

-There are 2 ATMs located in Smiths

-There are 2 active ATMs in Downtown Kingman 330 E. Beale St and 3360 E. Andy Devine Ave

ATM at the Walapai Market is available for cash withdrawal if you do mobile deposit.

## Treasury, IRS Launch New Tool to Help Non-Filers to Register for Economic Impact Payments

Submitted by: Hualapai Incident Response Team



### Treasury, IRS launch new tool to help non-filers register for Economic Impact Payments

**IRS.gov feature helps people who normally don't file get payments; second tool next week provides taxpayers with payment delivery date and provide direct deposit information**

IR-2020-69, April 10, 2020

WASHINGTON — To help millions of people, the Treasury Department and the Internal Revenue Service today launched a [new web tool](#) allowing quick registration for Economic Impact Payments for those who don't normally file a tax return.

The non-filer tool, developed in partnership between the IRS and the Free File Alliance, provides a free and easy option designed for people who don't have a return filing obligation, including those with too little income to file. The feature is available only on IRS.gov, and users should look for *Non-filers: Enter Payment Info Here* to take them directly to the tool.

"People who don't have a return filing obligation can use this tool to give us basic information so they can receive their Economic Impact Payments as soon as possible," said IRS Commissioner Chuck Rettig. "The IRS and Free File Alliance have been working around the clock to deliver this new tool to help people."

The IRS reminds taxpayers that Economic Impact Payments will be distributed automatically to most people starting next week. Eligible taxpayers who filed tax returns for 2019 or 2018 will receive the payments automatically. Automatic payments will also go in the near future to those people receiving Social Security retirement, survivors, disability (SDDI), or survivor benefits and Railroad Retirement benefits.

#### **How do I use the *Non-Filers: Enter Payment Info* tool?**

For those who don't normally file a tax return, the process is simple and only takes a few minutes to complete. First, visit IRS.gov, and look for "*Non-Filers: Enter Payment Info Here*." Then provide basic information including Social Security number, name, address, and dependents. The IRS will use this information to confirm eligibility and calculate and send an Economic Impact Payment. Using the tool to get your payment will not result in any taxes being owed. Entering bank or financial account information will allow the IRS to deposit your payment directly in your account. Otherwise, your payment will be mailed to you.

"*Non-Filers: Enter Payment Info*" is secure, and the information entered will be safe. The tool is based on Free File Fillable Forms, part of the Free File Alliance's offerings of free products on IRS.gov.

#### **Who should use the *Non-Filers* tool?**

This new tool is designed for people who did not file a tax return for 2018 or 2019 and who don't receive Social Security retirement, disability (SSDI), or survivor benefits or Railroad Retirement benefits. Others who should consider the *Non-Filers* tool as an option, include:

**Lower income:** Among those who could use *Non-Filers: Enter Payment Info* tool are those who haven't filed a 2018 or 2019 return because they are under the normal income limits for filing a tax return. This may include single filers who made under \$12,200 and married couples making less than \$24,400 in 2019.

**Veterans beneficiaries and Supplemental Security Income (SSI) recipients:** The IRS continues to explore ways to see if Economic Impact Payments can be made automatically to SSI recipients and those who receive veterans disability compensation, pension or survivor benefits from the Department of Veterans Affairs and who did not file a tax return for the 2018 or 2019 tax years. People in these groups can either use *Non-Filers: Enter Payment Info* option now or wait as the IRS continues to review automatic payment options to simplify delivery for these groups.

**Social Security, SSDI and Railroad Retirement beneficiaries with qualifying dependents:** These groups will automatically receive \$1,200 Economic Impact Payments. People in this group who have qualifying children under age 17 may use *Non-Filers: Enter Payment Info* to claim the \$500 payment per child.

**Students and others:** If someone else claimed you on their tax return, you will not be eligible for the Economic Impact Payment or using the *Non-Filer* tool.

**Coming next week: Automatic payments begin**

Eligible taxpayers who filed tax returns for either 2019 or 2018 and chose direct deposit of their refund will automatically receive an Economic Impact Payment of up to \$1,200 for individuals or \$2,400 for married couples and \$500 for each qualifying child. Individuals who receive Social Security retirement, survivors or disability benefits, SSDI or who receive Railroad Retirement benefits but did not file a return for 2019 or 2018 will automatically receive a payment in the near future.

**Coming next week: *Get My Payment* shows Economic Impact Payment date, helps with direct deposit**

To help everyone check on the status of their payments, the IRS is building a second new tool expected to be available for use by April 17. *Get My Payment* will provide people with the status of their payment, including the date their payment is scheduled to be deposited into their bank account or mailed to them.

An additional feature on *Get My Payment* will allow eligible people a chance to provide their bank account information so they can receive their payment more quickly rather than waiting for a paper check. This feature will be unavailable if the Economic Impact Payment has already been scheduled for delivery.

**More Information on Economic Impact Payments**

The IRS will post additional updates on [IRS.gov/coronavirus](https://www.irs.gov/coronavirus) on these and other issues.

Page Last Reviewed or Updated: 13-Apr-2020

**Walapai Market • Limits to Service and Goal**

*Submitted by: Hualapai Incident Response Team*

# WALAPAI MARKET

**Effectively immediately Monday, April 13, 2020**



To slow down the spread of COVID19 and limit exposure the Market will not be allowing any person (s) inside

Instead a Market Team member will greet you at the door and take your order

To best serve you, please Call 769-1500 ahead of time to place your order

Your order will be ready for pick up at the front door of the Market

Payment process at the register will remain the same with limited entry

ATM access will be available through the side entrance with limited entry

**Please wear a mask or facial covering and gloves (any type) for service**

Thank you for your cooperation! Stay Safe Hualapai

**For Questions and or Concerns Call Public Information 769-2312**

# WALAPAI MARKET

## OUR GOAL

The Walapai Markets goal is to help prevent the spread of the Coronavirus that has impacted the country and to keep team members and our visitors as safe as possible when visiting our establishment.

Our Goal is to be responsible & helpful to Hualapai and help prevent the spread of the Coronavirus

- We will wear gloves & masks when serving the community, handling cash, credit cards, and walk up orders made
- We will use Clorox wipes or sanitizers to disinfect areas, credit card holders, door handles, exits and entry doors anything that may encounter an infected person
- We will thoroughly wipe down all areas at the end of each day
- All wipes and sanitizer buckets will be replaced with fresh buckets and/or containers for the wipes
- Avoid touching your face
- Wash your hands, wash your hands for 20 seconds

## STAY SAFE HUALAPAI

Continue to participate in the preventive practices that have been posted in the community

Wash your hands frequently, practice social distancing, refrain from touching your face, wear a mask & gloves and follow the Stay at Home Order!

Call the Public Information Officer for questions and or concerns at 928-769-2312

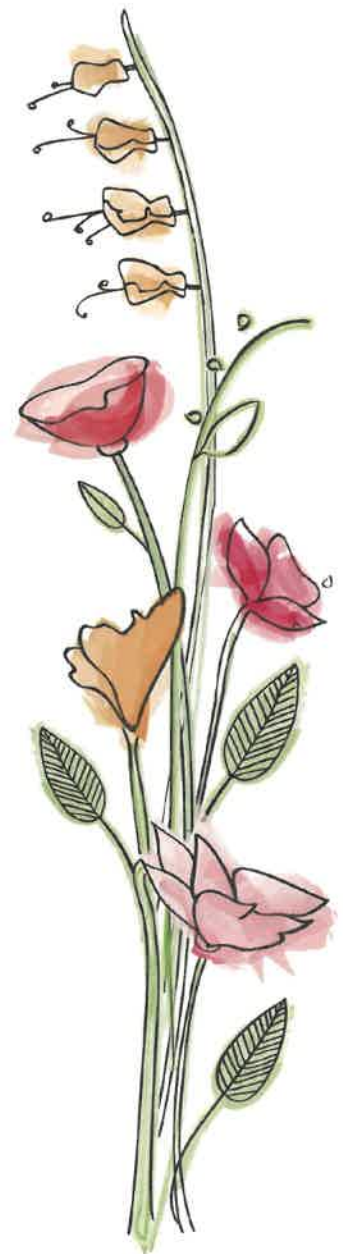

**Diamond Creek Restaurant • Hours of Operation & Limited Menu Updates**

*Submitted by: Consuela Bravo | Diamond Creek Restaurant*

*Service*  
**AT**



**WILL BE LIMITED TO  
TAKE OUT ONLY**

**Until Further Notice**

**[LIMITED MENU]**

**HOURS OF OPERATION**

**9:30am-6:00pm**

# diamond creek

RESTAURANT

## LIMITED MENU \$5 ea.

{Menu subject to change due to inventory}

### Breakfast

Available from  
9:30am-11:00am

- Breakfast Burrito  
(Bacon, Sausage, Ham or Spam)
- Breakfast Sandwich  
(Bacon, Sausage, Ham or Spam)
- Biscuits & Gravy

Breakfast Specials will be posted  
the night before

### Dinners

Available from  
4:00 pm – 6:00 pm

- Meatloaf, Mash & Gravy  
and Veggies
- Chicken Fried Steak, Mash  
& Gravy and Veggies

Additional Dinner Specials will  
be posted

### Lunch

Available from  
11:00am-6:00pm

- Cheeseburger and Fries
- Chicken Sandwich and Fries
- Chicken Wings
- Hualapai Wrap and Fries
- Chicken Strips and Fries
- Hualapai Taco
- Hualapai Stew
- Deli Sandwich and Fries  
(Ham or Turkey)

Lunch Specials will be posted the  
night before

Curbside Available starting  
Sunday, April 5, 2020

*These are special discounted prices to accommodate the community during the restaurant closure. Credit card payments are preferred. If paying with cash, guests entering the restaurant will be requested to maintain social distance per CDC requirements. Thank you for your understanding Diamond Creek Restaurant Management.*

**Grand Canyon Resort Corporation • Basket Auction: Winner Announced Friday, May 1<sup>st</sup>**

*Submitted by: Nicholas Cabrera | Grand Canyon Resort Corporation*

# BASKET AUCTION

The Grand Canyon Resort Corporation is auctioning a Apache Vase Basket.

## Basket Bid #1901



Auction Opens: February 21, 2020  
Auction Closes: April 30, 2020  
Announcement: **May 1, 2020**

### REQUIREMENTS:

- A minimum bid of \$100
- Must be an enrolled Hualapai Tribal Member
- Bid must be received by 5PM on April 30, 2020

### SUBMITTING YOUR BID:

Please submit your bid, along with the following information:

- Basket Bid #1901
- Full Name
- Contact Number
- Amount of bid, no less than \$100

### Apache Vase Basket

- Height—21 inches
- Width—18 inches
- Basket only
- Does not include rug, stand or items below

### BIDS MAY BE MAILED TO:

Grand Canyon Resort Corporation  
Attn: Procurement Department  
PO Box 359  
**Peach Springs, AZ 86434**

The Grand Canyon Resort Corporation is auctioning a Apache Burden Basket.

## Basket Bid #1902



Auction Opens: February 21, 2020  
Auction Closes: April 30, 2020  
Announcement: **May 1, 2020**

### REQUIREMENTS:

- A minimum bid of \$100
- Must be an enrolled Hualapai Tribal Member
- Bid must be received by 5PM on April 30, 2020

### SUBMITTING YOUR BID:

Please submit your bid, along with the following information:

- Basket Bid #1902
- Full Name
- Contact Number
- Amount of bid, no less than \$100

### Apache Burden Basket

- Height—16 inches
- Circumference—22 inches
- Basket only
- Does not include rug, stand or items below

### OR HAND DELIVERED TO:

Administrative Office -  
Procurement Department in Peach Springs.  
Bids must be in a sealed envelope.

All interested bidders are welcome to inspect the basket.

For more information, you may contact the Procurement Department at (928) 769-2419

**GCRC Employees are not eligible to bid at this time.**

---

**Department of Health & Human Services • Now Hiring—Security Guard**

*Submitted by: Hualapai Incident Response Team*

---



DEPARTMENT OF HEALTH & HUMAN SERVICES

Public Health Service  
Indian Health Service

---

Colorado River Service Unit  
Parker Indian Health Center  
12033 Agency Road  
Parker, AZ 85344

## Now Hiring!

Security Guard  
Peach Springs Health Center  
Open Until Filled, \$31,674 - \$41,174 Per Yr.  
Monday - Friday, 8:00 am - 5:00 pm  
40 hours per week

Position eligible for Health Benefits: Vision,  
Dental and Life Insurance, Includes Leave  
(Annual/Sick)

### Contact Information:

Tracey Bement, (928) 669-2137 ext. 7518,  
[tracey.bement@ihs.gov](mailto:tracey.bement@ihs.gov)  
Terilyn Gary, (928) 669-2137 ext. 7521,  
[terilyn.gary@ihs.gov](mailto:terilyn.gary@ihs.gov)

---

### Peach Springs Unified School District • Vacant Positions

*Submitted by: Jaime Cole | Peach Springs Unified School District*

---

**Peach Springs Unified School District #8**  
**Peach Springs, AZ 86434**  
**Phone: 928-864-7100**

PSUSD is an Equal Opportunity Employer; we provide a safe and supportive working environment with great pay and benefits. Location is approximately 1.5 hours west of Flagstaff, and 2 hours east of Las Vegas, 4 hours from Phoenix. Great schedule: 4 day work week, 10 hours a day M-Th.

#### **Classified/Certified Support Positions:**

- \*Bus Driver/Custodian (beginning \$18 an hour, all paved roads within 5 miles radius)
- \*Kitchen manager- kitchen 4 days a week 5am-3 pm, \$18 an hour
- \*Business Manager- 4 days a week, experience with school accounting, great benefits

#### **Certified:**

- \*Assistant K-8 - Work with Teachers and Instructional coach(s) to ensure best practices in Instructional services and safe environment.
- \*Elementary teachers- Small class sizes, full curriculum and technology provided in each class, great pay, 4 days a week (156-day contract), housing available, fully paid insurance benefits, and matching retirement- beginning salary \$55,000 (base \$52,500 for SY21 with \$2,500 retention for completing contract= \$55,000 beginning rate)
- \*Behavior interventionist – similar to Dean of Students beginning \$55,000
- \*PE Teacher, computer teacher/testing coordinator, Hualapai culture teacher- same pay scale at elementary teachers

Closing: Until Filled

Apply online [psusd8.org](http://psusd8.org), [colej@psusd8.org](mailto:colej@psusd8.org) and/or contact Superintendent Jaime Cole 928-864-7100



# HEALTH & SAFETY INFORMATION

## Peach Springs Health Center • Update

Submitted by: Hualapai Incident Response Team

### Peach Springs Health Center (PSHC) Update

April 15, 2020

The clinic **remains open** during business hours: Monday through Friday, 8:00 am to 5:00 pm providing limited services. **No visitors allowed, currently still seeing acute care patients on a walk-in basis, we ask you please call first (928-769-2900) and talk to a doctor to see if you need to come in. If your child needs immunizations or a well-child visit, please call first to arrange this visit.**

**Please call first (928-769-2992) if you have a prescription to renew or refill.**

We continue to work towards **slowing** the potential spread of the CoVid-19 virus, there are **50 confirmed COVID-19** cases in the **Mohave County** and **seven confirmed positive cases** in the Peach Springs community at this time. (If you have been identified as someone who has come in contact with a person tested for COVID-19, you will be receiving a phone call from our public health nurse or clinic staff to check on your wellbeing.)

Effective April 15, there will be designated parking areas for patients that require medical screenings and prescription pick-up, please note the two designated areas. There will be one-way directional flow of traffic coming into the clinic parking, please be cautious and look out for other traffic or patients. All clinic staff vehicles will be parked in a designated area (south end of clinic) to allow parking spaces for patients in the two designated patient areas. All GSA vehicles have been relocated to allow additional parking. (Currently, clinic staff enter through a designated entrance to reduce any crowding of patients/staff at the designated patient screening area).

Due to recent events, the dental clinic will be closed tomorrow, April 16, 2020, and resume clinic Tuesday, April 21<sup>st</sup> and continue every Tuesday/Thursday.

If you think you have been exposed to the Coronavirus, develop a fever or symptoms, such as cough or difficulty breathing, **please call first** to the Peach Springs Health Clinic at **928-769-2900** for medical advice.

We will continue to keep you updated and informed on any Peach Springs Health Center clinic operations. We want to reassure the Hualapai Tribe that the Indian Health Service is here to serve the community to the best of our abilities and available resources. As we continue to receive updates from the government, we tailor our plans accordingly with the new guidance. Thank you all for your cooperation as we respond to the current national emergency.

Respectfully,

Perfecto B. Cronemeyer  
USN(Ret), BSHA, MBA  
Acting Health System Administrator  
Peach Springs Health Center  
(928)769-2906 HSA Administrative Assistant  
(928)575-6681 Direct Cell \*(preferred)

4/15/2020

## Hualapai Incident Response Team • COVID-19 Information

Submitted by: Hualapai Incident Response Team

### How COVID-19 Spreads

COVID-19 is a new disease and we are still learning about how it spreads and the severity of illness it causes.

#### Person-to-person spread

The virus is thought to spread mainly from person-to-person.

- Between people who are in close contact with one another (within about 6 feet).
- Through respiratory droplets produced when an infected person coughs, sneezes or talks.
- These droplets can land in the mouths or noses of people who are nearby or possibly be inhaled into the lungs.
- Some recent studies have suggested that COVID-19 may be spread by people who are not showing symptoms.
- Maintaining good social distance (about 6 feet) is very important in preventing the spread of COVID-19.

#### Spread from contact with contaminated surfaces or objects

It may be possible that a person can get COVID-19 by touching a surface or object that has the virus on it and then touching their own mouth, nose, or possibly their eyes. This is not thought to be the main way the virus spreads, but we are still learning more about this virus. CDC recommends people practice frequent “hand hygiene,” which is either washing hands with soap or water or using an alcohol-based hand rub. CDC also recommends routine cleaning of frequently touched surfaces.

#### How easily the virus spreads

How easily a virus spreads from person-to-person can vary. Some viruses are highly contagious, like measles, while other viruses do not spread as easily. Another factor is whether the spread is sustained, which means it goes from person-to-person without stopping.

- The virus that causes COVID-19 is spreading very easily and sustainably between people.
- Information from the ongoing COVID-19 pandemic suggest that this virus is spreading more efficiently than influenza, but not as efficiently as measles, which is highly contagious.

COVID-19 is thought to spread mainly through close contact from person-to-person in respiratory droplets from someone who is infected. People who are infected often have symptoms of illness. Some people without symptoms may be able to spread virus.

### Tracing Contacts of Covid-19 patients

When we have a **confirmed positive or suspected Covid-19 patient** we talk to the patient and family about who they have had contact with in the last 14 days and start performing tracers starting with:

- **All household members** which is anyone with at least one overnight stay +/- 7 days from patient's illness onset, and the patient may have resided in >1 household.
- A **close contact** is anyone who was within 6 feet of the case patient for more than 30 minutes or anyone who had direct contact with infectious secretions of the case patient (e.g., being coughed on). **This includes healthcare staff.**
- A **high risk contact** is a person who fits one or more of the following: aged 65 years and older, who lives in a nursing home or long-term care facility, who has a chronic condition such as: chronic lung disease or moderate to severe asthma, serious heart condition, immunocompromised including cancer treatment, severe obesity (body mass index [BMI] >40), diabetes, renal failure, liver disease, or pregnant. (Pregnancy should be monitored since they are known to be at risk with severe viral illness, however, to date data on COVID-19 has not shown increased risk.)
- Anyone who has had contact with a positive Covid patient will be put on home isolation for 14 days.
- If you know you have had contact with a positive Covid patient please contact the Peach Springs clinic at 928-769-2900 so we may assist with monitoring of symptoms and give you home isolation guidelines.
- Any person that has been tested for Covid-19 will be put on home isolation as well.

# Use of Cloth Face Coverings to Help Slow the Spread of COVID-19

## How to Wear Cloth Face Coverings

Cloth face coverings should—

- fit snugly but comfortably against the side of the face
- be secured with ties or ear loops
- include multiple layers of fabric
- allow for breathing without restriction
- be able to be laundered and machine dried without damage or change to shape

## CDC on Homemade Cloth Face Coverings

CDC recommends wearing cloth face coverings in public settings where other social distancing measures are difficult to maintain (e.g., grocery stores and pharmacies), **especially** in areas of significant community-based transmission.

CDC also advises the use of simple cloth face coverings to slow the spread of the virus and help people who may have the virus and do not know it from transmitting it to others. Cloth face coverings fashioned from household items or made at home from common materials at low cost can be used as an additional, voluntary public health measure.

Cloth face coverings should not be placed on young children under age 2, anyone who has trouble breathing, or is unconscious, incapacitated or otherwise unable to remove the cloth face covering without assistance.

The cloth face coverings recommended are not surgical masks or N-95 respirators. Those are critical supplies that must continue to be reserved for healthcare workers and other medical first responders, as recommended by current CDC guidance.

## Should cloth face coverings be washed or otherwise cleaned regularly? How regularly?

Yes. They should be routinely washed depending on the frequency of use.

## How does one safely sterilize/clean a cloth face covering?

A washing machine should suffice in properly washing a cloth face covering.

## How does one safely remove a used cloth face covering?

Individuals should be careful not to touch their eyes, nose, and mouth when removing their cloth face covering and wash hands immediately after removing.

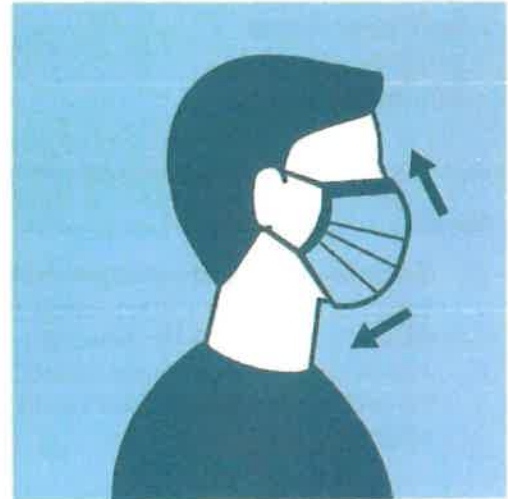

## Sewn Cloth Face Covering

### Materials

- Two 10"x6" rectangles of cotton fabric
- Two 6" pieces of elastic (or rubber bands, string, cloth strips, or hair ties)
- Needle and thread (or bobby pin)
- Scissors
- Sewing machine



### Tutorial

1. Cut out two 10-by-6-inch rectangles of cotton fabric. Use tightly woven cotton, such as quilting fabric or cotton sheets. T-shirt fabric will work in a pinch. Stack the two rectangles; you will sew the cloth face covering as if it was a single piece of fabric.

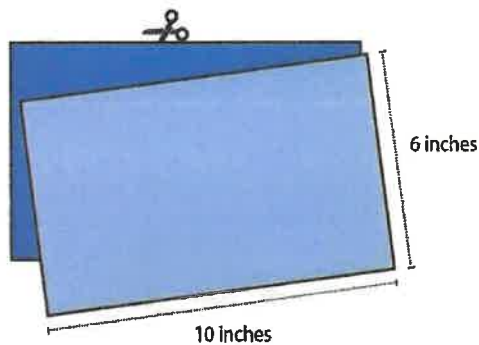

2. Fold over the long sides  $\frac{1}{4}$  inch and hem. Then fold the double layer of fabric over  $\frac{1}{2}$  inch along the short sides and stitch down.

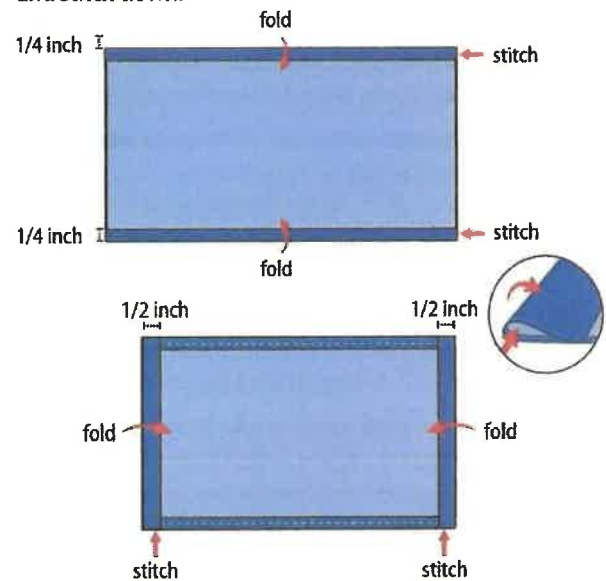

3. Run a 6-inch length of  $\frac{1}{8}$ -inch wide elastic through the wider hem on each side of the cloth face covering. These will be the ear loops. Use a large needle or a bobby pin to thread it through. Tie the ends tight. Don't have elastic? Use hair ties or elastic head bands. If you only have string, you can make the ties longer and tie the cloth face covering behind your head.

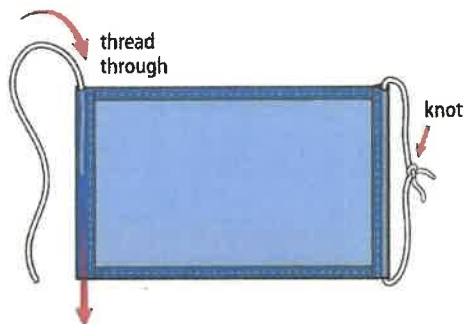

4. Gently pull on the elastic so that the knots are tucked inside the hem. Gather the sides of the cloth face covering on the elastic and adjust so the cloth face covering fits your face. Then securely stitch the elastic in place to keep it from slipping.

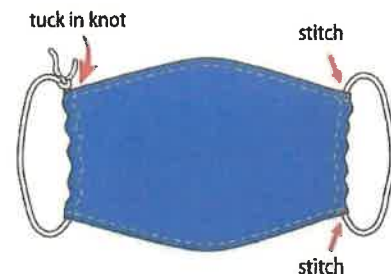

## Quick Cut T-shirt Cloth Face Covering (no sew method)

### Materials

- T-shirt
- Scissors

### Tutorial

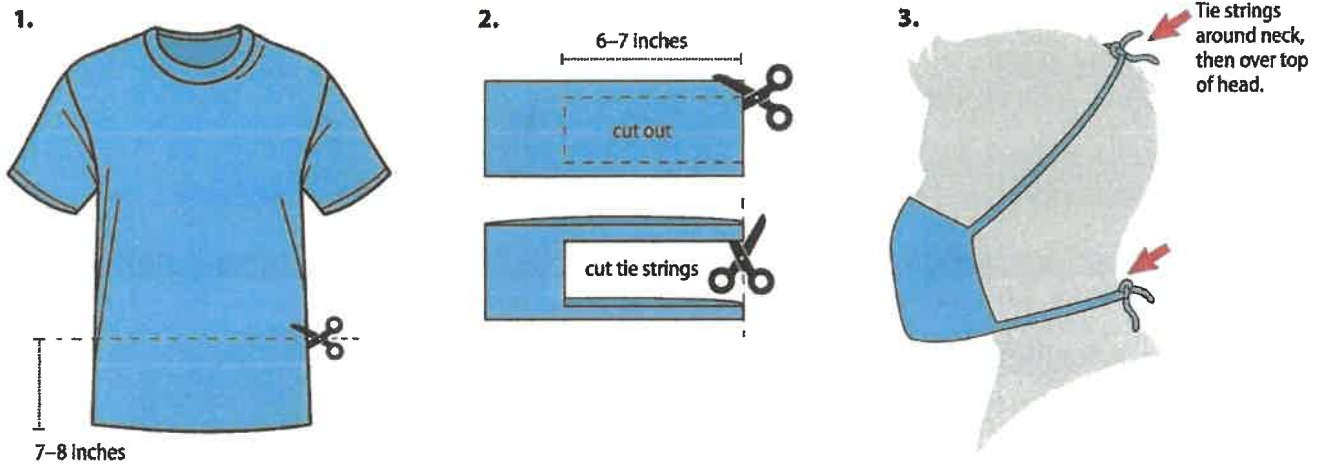

## Bandana Cloth Face Covering (no sew method)

### Materials

- Bandana (or square cotton cloth approximately 20"x20")
- Coffee filter
- Rubber bands (or hair ties)
- Scissors (if you are cutting your own cloth)

### Tutorial

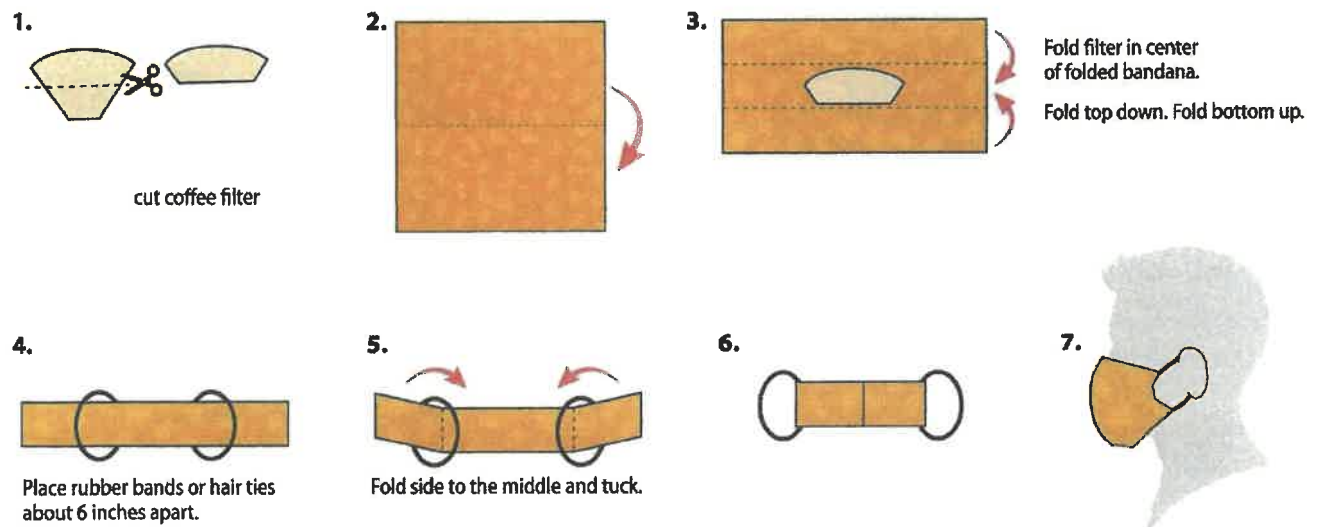

## In-Home Resource for Families and Young Children

- <https://pbskids.org/>  
Videos, activities, and lessons
- <https://www.firstthingsfirst.org/resources/parent-kit/>  
Information and inspiration for parents and caregivers of babies, toddlers and preschoolers
- <https://www.firstthingsfirst.org/resources/learnthroughplay/>  
Informational videos for parents and caregivers of babies, toddlers and preschoolers
- <https://www.sesamestreet.org/toolkits/healthyhabits>  
Activities and videos
- <https://lol.disney.com/>  
Online coloring, videos, and games
- <https://www.mindheart.co/descargables>  
Short book to support and reassure our children about COVID-19
- <https://classroommagazines.scholastic.com/support/learnathome/grades-prek-k.html>  
Activities, lessons, and games
- <https://www.splashlearn.com/>  
Interactive games
- <https://www.education.com/resources/preschool/>  
Lessons, hands on activities, printable worksheets, and interactive stories



[www.birthtofivehelpline.org](http://www.birthtofivehelpline.org)

Arizona's only toll-free helpline for parents, caregivers and professionals with questions or concerns about children ages birth to 5.

**The call and services are FREE!**

Child development specialists are available Monday through Friday from 8:00 a.m. to 8:00 p.m.

Topics include: Sleep, Child Development, Fussiness/Colic, Challenging Behaviors, Parenting, Feeding/Nutrition, Community Resources, and Support to Child Care/Preschools.



2850 N. 28th St. • Phoenix, AZ 85018 • 602-266-5816 • [swhd.org](http://swhd.org)

SUPPORTED BY

FIRST THINGS FIRST



Steps to Register for Bright by text

1. Open a new text conversation on your cell phone
2. Type "274448" in the subject space.
3. Type "ARIZONAPBS" in the text space (ALL CAPITAL letters and NO SPACES).
4. A message will pop up asking for your child's date of birth. Input it as MMDDYY
5. It will then ask you to confirm it by texting "Y"
6. Enter your zip code when asked.
7. It will then ask you to confirm it by texting "Y"
8. Congratulations, you have completed your registration!

## COVID-19 Disease and Water

Amy E. Kirby, PhD MPH  
Environmental Microbiologist

Tribal Healthy Homes Network Webinar

April 9, 2020

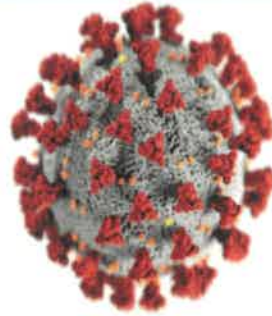

[cdc.gov/coronavirus](https://www.cdc.gov/coronavirus)



## COVID-19: What To Do if You Are Sick

- Stay home. Most people recover at home without needing medical care.
- Stay away from people as much as possible.
- Keep your distance and cover your coughs and sneezes if you must be around other people.
- Clean your hands often.
- Avoid sharing personal household items.
- Clean and disinfect frequently touched objects and surfaces.
- Monitor your symptoms for emergency warning signs, including trouble breathing.
- Get medical care quickly, but call ahead.

### Discontinue home isolation

- **With COVID-19 test**
  - No fever without fever-reducing medicine, AND
  - Other symptoms have improved AND
  - Tested negative 2x in a row, 24 hrs. apart
- **Without COVID-19 test**
  - No fever for 72 hrs. without fever-reducing medicine, AND
  - Other symptoms have improved AND
  - 7 days have passed since symptoms began

## COVID-19: How It Spreads

- The virus is thought to spread mainly from person to person.
  - Between people who are in close contact with one another (within about 6 feet)
  - Through respiratory droplets produced when an infected person coughs or sneezes
- These droplets can land in the mouths or noses of people who are nearby or possibly be inhaled into the lungs.
- These droplets can contaminate surfaces. Other people may pick up the virus by touching contaminated surfaces.



## COVID-19: How To Clean And Disinfect Your Home

- Common household cleaners and disinfectants are effective
- Follow label instructions for use (dilutions for use, contact time, and appropriate protective equipment)
- Household bleach can be diluted (1/3 cup of bleach into a gallon of water)
- Focus on high touch surfaces like remote controls, toilet handles, and light switches
- If surfaces are dirty, clean them before disinfecting



## COVID-19: If Someone In Your House Is Sick

- Separate sick people from well people
  - Set up a sick room
  - If possible, set up a sick bathroom
- Limit sick room cleaning to as-needed
- Sick person should wear a cloth face covering when a caregiver is in the room
- After sick person has recovered, close off sick room and wait up to 24 hours before cleaning and disinfecting
  - If possible, open windows to increase air flow



## COVID-19: Prevention & Treatment

### Everyday preventive actions for respiratory illnesses

- Avoid touching your eyes, nose, and mouth with unwashed hands.
- Avoid close contact with people who are sick.
- Stay home when you are sick.
- Cover your cough or sneeze with a tissue, then throw it away.
- Wash your hands often with soap and water for at least 20 seconds.
  - Use an alcohol-based hand sanitizer with at least 60% alcohol if soap and water are not readily available.
- Clean and disinfect frequently touched objects and surfaces.

### Treatment

- No specific antiviral treatment licensed for COVID-19
- Supportive care to
  - Relieve symptoms
  - Manage pneumonia and respiratory failure



## COVID-19: CDC Resources

- Latest COVID-19 information for the public [www.cdc.gov/coronavirus](https://www.cdc.gov/coronavirus)
- Preparing your home: <https://www.cdc.gov/coronavirus/2019-ncov/daily-lifecoping/checklist-household-ready.html>
- Caring for someone at home: <https://www.cdc.gov/coronavirus/2019-ncov/ifyou-are-sick/care-for-someone.html>
- Handwashing information: <https://www.cdc.gov/handwashing/index.html>
- Cloth face coverings: <https://www.cdc.gov/coronavirus/2019-ncov/preventgetting-sick/diy-cloth-face-coverings.html>
- Guidance for workplaces: <https://www.cdc.gov/coronavirus/2019ncov/community/guidance-business-response.html>



CLEAN AIR. SAFE HOMES.  
HEALTHY LIVES.

**AILEEN GAGNEY**  
MA.ARCH, HHS, GA-C, CLR, DST  
TECHNICAL ADVISOR AND TRAINER  
TRIBAL HEALTHY HOMES NETWORK

THERE ARE DISTINCTIONS!  
Safer Products

EPA SAFER CHOICE

Meets US EPA Safer Product Standards

<https://www.epa.gov/saferchoice>



## SAFE AND PROPER USE OF DISINFECTANTS

AILEEN GAGNEY MA.ARCH, HHS, GA-C  
TECHNICAL ADVISOR AND TRAINER  
TRIBAL HEALTHY HOMES NETWORK  
AGAGNEY@THHNW.ORG



### STEP 1: READ THE LABEL



### Types of Sanitizers and Disinfectants:

- Bleach
- Sanitizers
- Disinfecting Wipes
- Antibacterial Sprays
- Isopropyl Alcohol
- Safer Choice Products
- Hydrogen Peroxide
- Hand Sanitizers
- etc.....

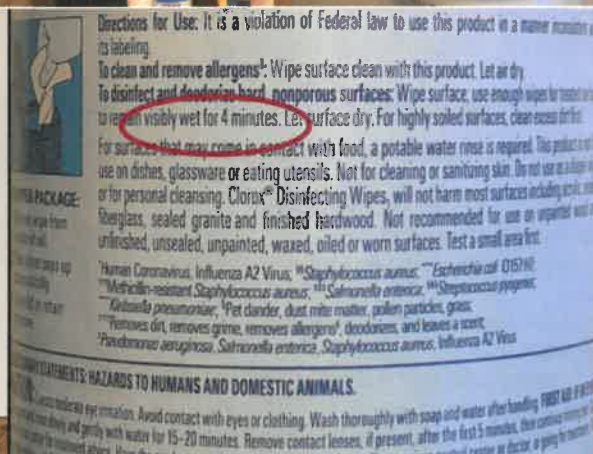

THERE ARE DISTINCTIONS!  
Conventional Products (such as household bleach)

- Please read the label and follow instructions
- Allow proper ventilation during and after application
- **DO NOT MIX** with household products or chemicals
- Must leave on surface for 1 minute
- Rinse after use
- Dilution rates: 5 T bleach/gallon of water  
4 t bleach/quart of water



### STEP 2: TAKE PRECAUTIONS



**STEP 3: PREPARE SURFACE (IF NECESSARY)**  
Clean with Soap and Water, Rinse and Dry



**STEP 7: FOR SURFACES THAT MAY COME IN CONTACT WITH FOOD, a Potable Water Rinse is Required!**

**STEP 4: FOLLOW INSTRUCTIONS CAREFULLY**

**STEP 8: WASH AND DRY HANDS**



**STEP 5: LEAVE SURFACES VISIBLY WET** for Required Contact Time (15 seconds – 10 minutes) and Dispose of wipes in trash (NOT down the toilet)

**SAFE AND PROPER USE OF DISINFECTANTS**



Aileen Gagney MA. Arch, HHS, GA-C, CLR, DST  
Technical Advisor and Trainer  
Tribal Healthy Homes Network  
[agagney@thnhw.org](mailto:agagney@thnhw.org) 1.800.717.2118

*Thank you!*

**STEP 6: REMOVE AND DISCARD GLOVES**



# COMMUNITY MESSAGES

**Happy 3<sup>rd</sup> Birthday Eldon Trice Marshall**

*We would like to wish our baby Eldon T. Marshall (4-18-2020) a Happy 3<sup>rd</sup> Birthday. My, how it seems like yesterday you were born. Watching you grow each day, hearing your laughs and cries. Watching you do things to make us laugh and entertain us with your silly faces just being silly. We are so blessed to have your heart and soul a part of our spirits. You are deeply blessed and loved so much by Mom, Dad, all your siblings & Grandmothers*



**Hualapai Primary Election • Candidate Vivian Sue Parker***Submitted by: Vivian Sue Parker*

April 12, 2020

Gamyu:

It is Easter Sunday. I feel fortunate my tummy is full and the house is warm. My name is Vivian Sue Parker, the daughter of the late Barbara Mukeche and Sam Wong. I am the proud mother of Fawn Parker and Chelsea Bender. I have eight grandchildren, Kyler, Zaharia, Zahmira, Marly, Isaac, Isaiah, Lj and Charlotte.

I am a Hualapai/Chinese woman, who returned to Peach Springs 8 ½ years ago. My home is here in Peach Springs and we come from Hakisigaela Ba' (Big Sandy). I am happy to be back in the Hualapai world.

I want to introduce myself as a candidate for a seat with the Hualapai Tribal Council. I have thought and prayed as to taking this step in my life. I believe that it is time for new faces, thoughts, values and voices to be part of our Tribal Council.

I believe in the process of running for Tribal Council and accept the challenge of taking this on with my heart, soul, and mind.

I believe that I am a Hualapai woman, who will say what needs to be heard.

I believe in my courage and commitment no matter what life has brought my way.

I believe my voice shows what I value in life, God, my family, and Hualapai tribal members welfare.

I have had the opportunity to sit in on many Tribal Council meetings during the time I have returned from Washington State. In these meetings, I have heard, learned and voiced my concerns on topics such as our water rights, per capita, rights of Hualapai tribal members, how the Constitution and Code of Ethics relates to the Tribal Council performing their work, etc.

Being in Tribal Council meetings one of the most important message I speak about is to educate the Hualapai tribal members, not only here in Peach Springs, but for the other more than half of our Tribe that lives outside the reservation when discussions are held in Tribal Council meetings.

I have often spoke of using our resources we have here as a Tribe in Peach Springs; utilizing the radio station by recording live Tribal Council meetings. Going through the Corona virus at this time, I witness the Tribal Council being heard live over the internet. This is a positive change for us when we need to hold onto something strong thereby giving us hope.

This hope is something I want to bring to the common people, hope to bring trust that lasts beyond the election on June 7<sup>th</sup>

Please come out and vote. Now is the time to begin evaluating who you want in our Tribal Council the next four years. Exercise your voice as a Hualapai tribal member through voting.

With pride,

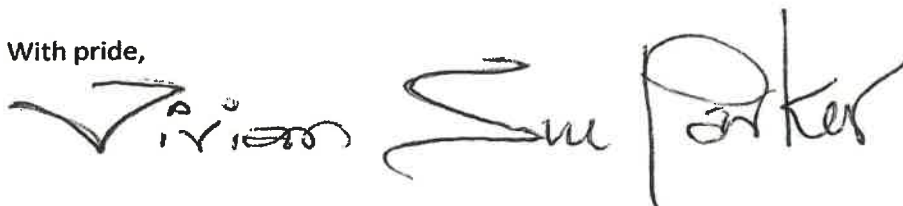
A handwritten signature in black ink that reads "Vivian Sue Parker". The signature is written in a cursive, flowing style. The word "Vivian" is on the left, "Sue" is in the middle, and "Parker" is on the right, all connected together.

# HELLO!

**I am a VIRUS,  
cousins with the flu and  
the Common Cold**

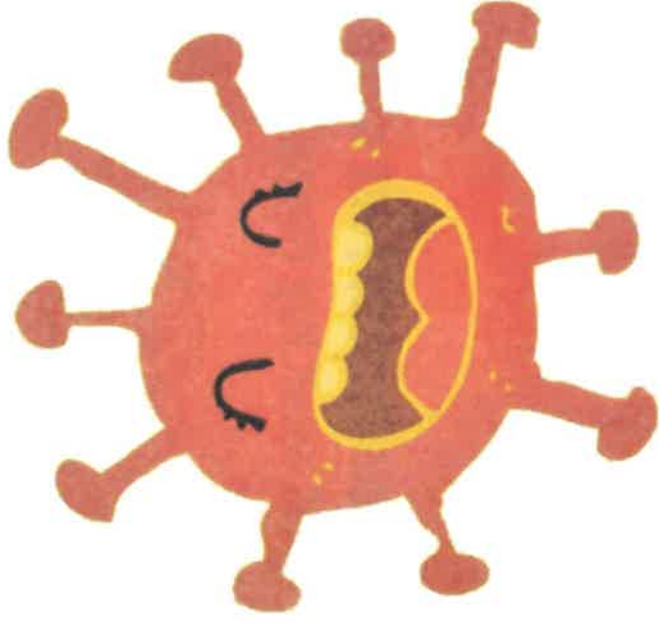

**My name is Coronavirus**

**I love to travel...**

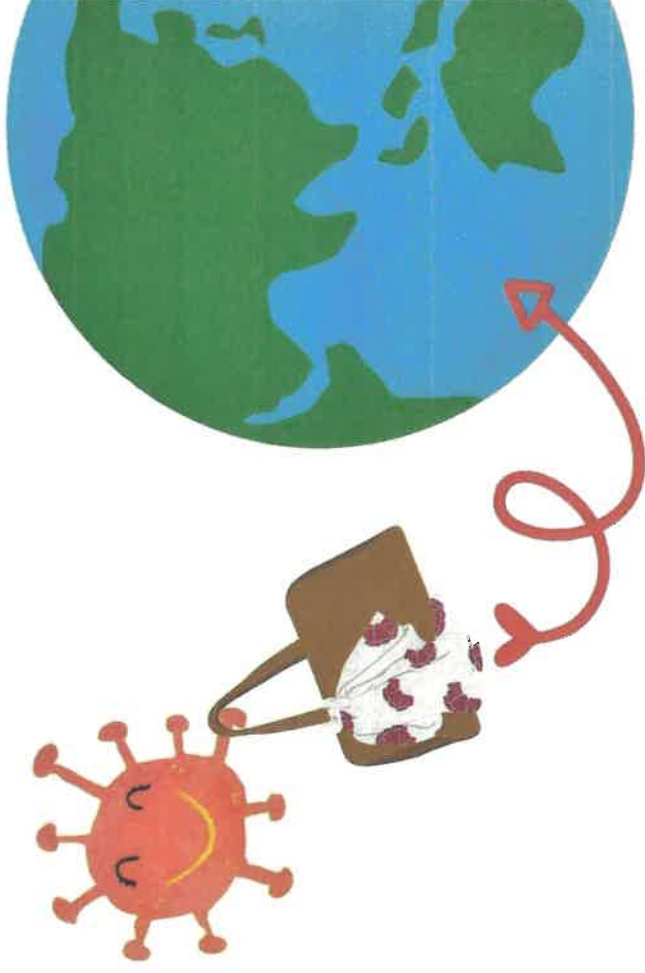

**and to jump  
from hand to  
hand to say Hi**

**HIGH  
FIVE**



MANUELA MOLINA - @MINDHEART.KIDS

WWW.MINDHEART.CO

CC BY-NC-SA 4.0 INTERNATIONAL PUBLIC LICENSE

Have you heard about me?

YES

NO

I can understand you  
feel...

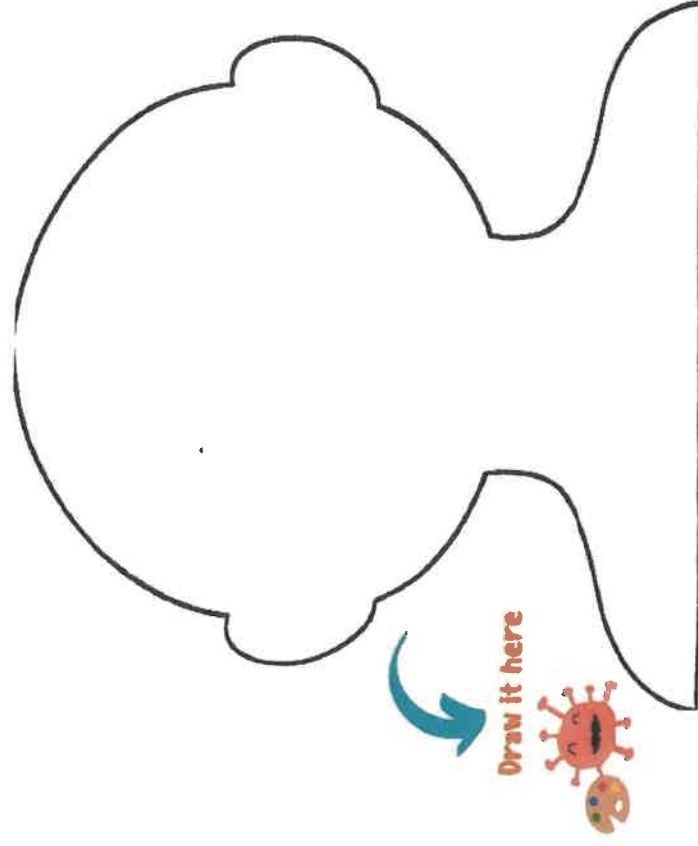

And how do you feel when  
you hear my name?

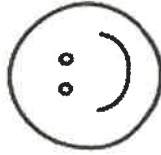

Relaxed

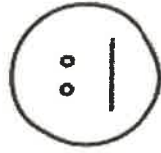

Confused

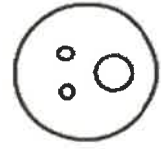

Worried

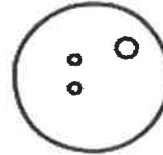

Curious

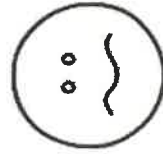

Nervous

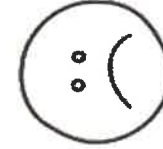

Sad

...I would feel the same way



**Sometimes adults get worried when they read the news or see me on TV**

**But I am going to explain myself...**



**THAT'S ME!**

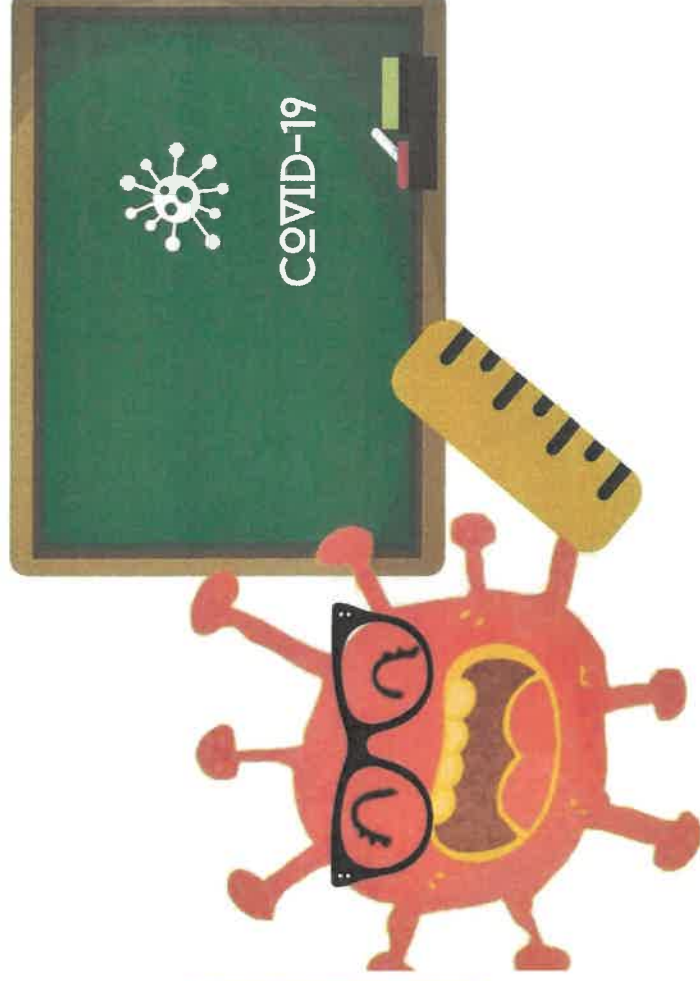
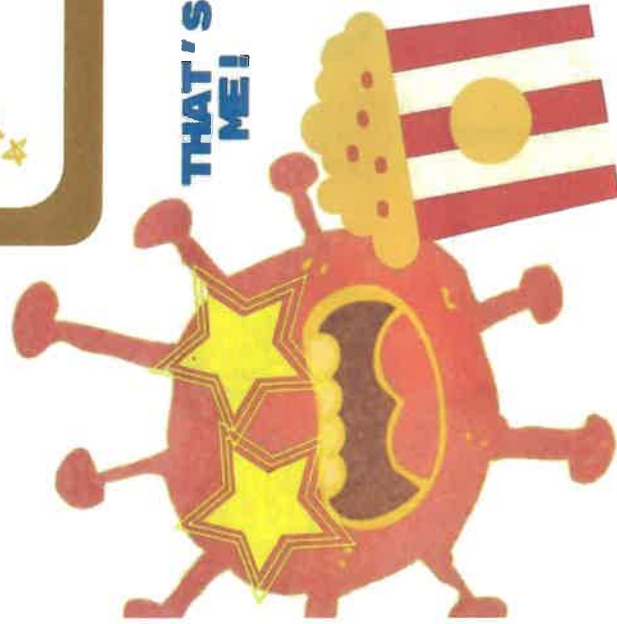

**So you can understand...**



**When I come to visit, I bring...**



**But I don't stay with people for long, and almost everyone gets better**

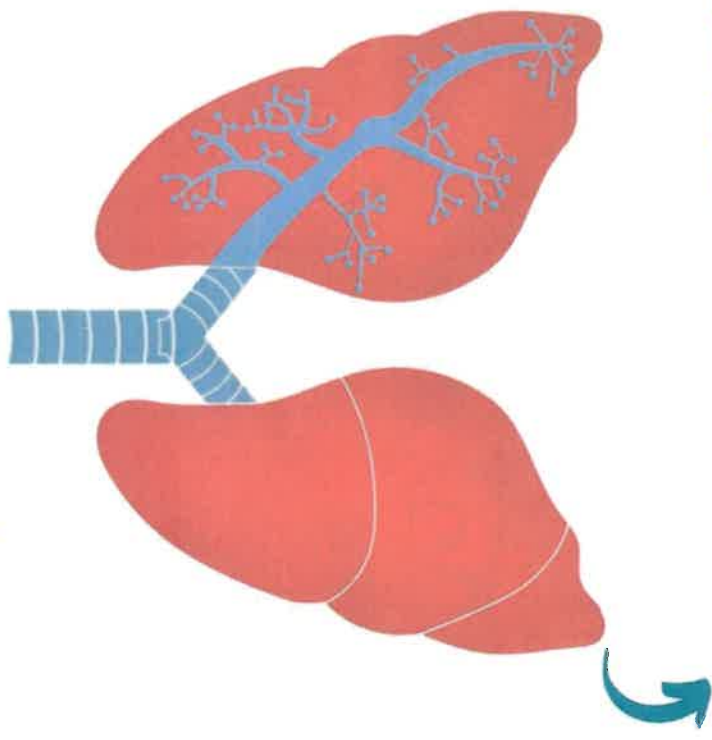

**Difficulty breathing**



**Fever**



**Cough**

**Just like when you get a scrape on your knee and it heals**

**BYE BYE...**

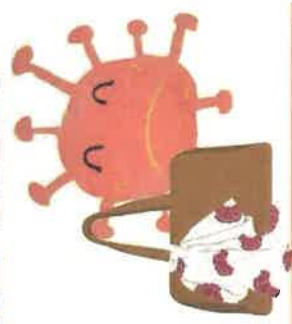

**Don't worry!**

**And you can help...**

**The adults who take care of you:**

**will keep you safe**

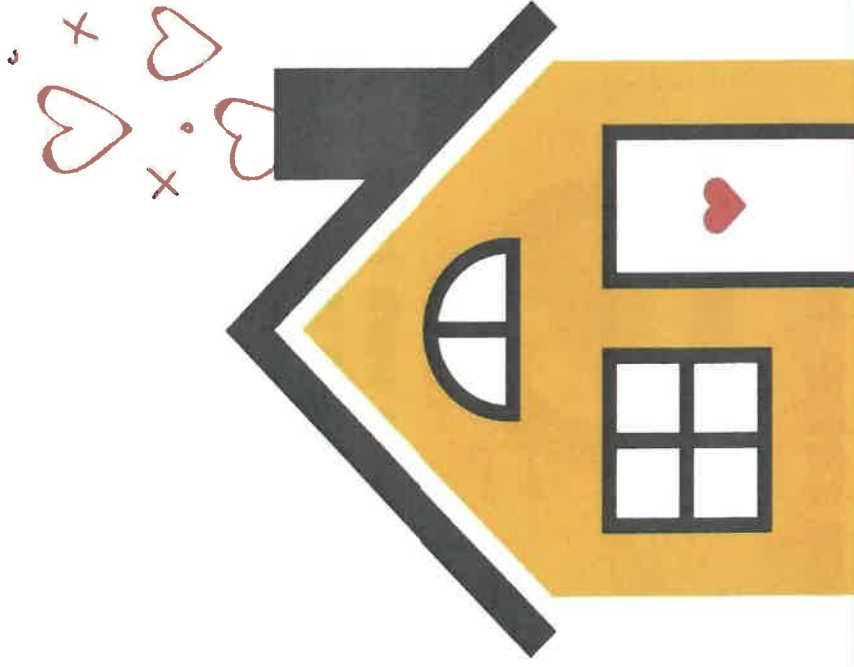

**By washing your hands  
with soap and water  
while singing a song**

**1**



**You can sing your favorite song,  
the happy birthday song, or the  
alphabet song**

**2**



**By using hand sanitizer  
and letting it dry on  
your hands**



**Without moving them count to 10**

**1, 2, 3, 4, 5, 6, 7, 8, 9, 10**

**Once your hands are dry you can get  
back to playing!!**



**If you do all that  
I will not come to visit**



**while the doctors work to find a vaccine  
that will allow me to say hi  
without getting you sick.**

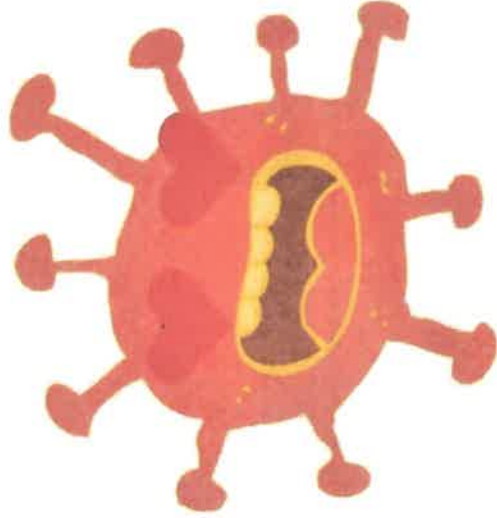

# THE END

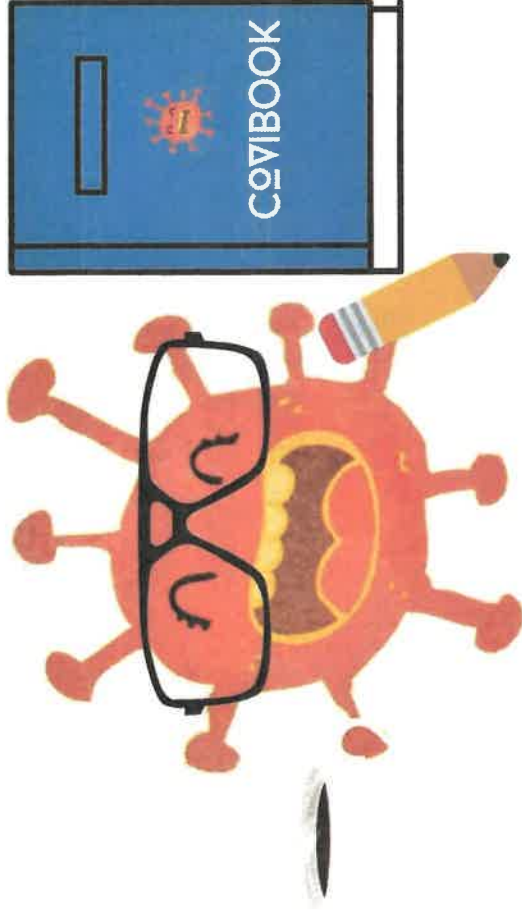

**Download this PDF here:**

**[www.mindheart.co/descargables](http://www.mindheart.co/descargables)**

**Author:  
Manuela Molina Cruz  
Instagram: @mindheart.kids  
[manuela\\_825@hotmail.com](mailto:manuela_825@hotmail.com)**

MANUELA MOLINA - @MINDHEART.KIDS  
[WWW.MINDHEART.CO](http://WWW.MINDHEART.CO)

CC BY / NC-SA 4.0 INTERNATIONAL PUBLIC LICENSE

CC BY-NC-SA 4.0 International Public License